

THIS DRAWING IS UNPUBLISHED. RELEASED FOR PUBLICATION  
 © COPYRIGHT BY TYCO ELECTRONICS CORPORATION. ALL RIGHTS RESERVED.

LOC	DIST	REVISIONS				
P	LTR	DESCRIPTION	DATE	DWN	APVD	
AF	50	L1	ECR-06-023927(REDRAWN IN AUTOCAD)	27JUN06	HMR	GP

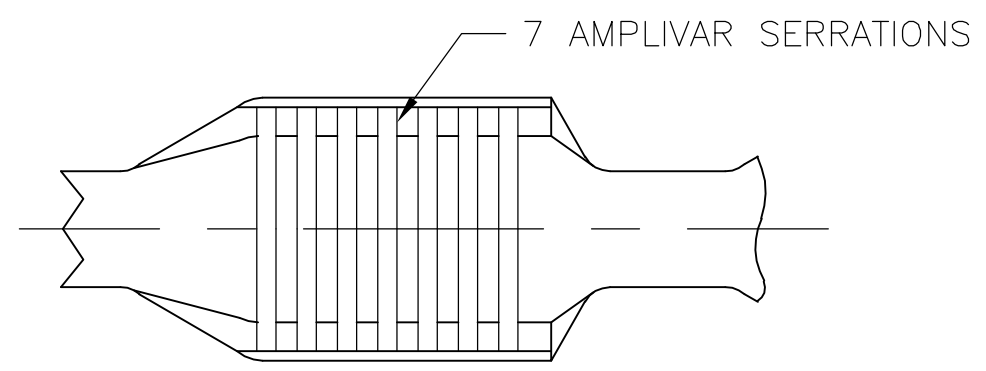

- CONTINUOUS STRIP ON REELS.
- DIMENSIONS IN BRACKETS ARE IN INCHES.
- FOR ADDITIONAL INFORMATION, SEE APPLICATION SPEC. 114-2002.
- CRIMP WIDTH: .110 F TYPE (AMPLIVAR PIGTAIL)  
 CRIMP HEIGHT (±.002)=(TOTAL CMA+9,400)/190,500  
 GENERAL APPLICATION GUIDELINES MUST BE FOLLOWED AS SPECIFIED IN CATALOG #82221  
 FOR APPLICATOR INFORMATION CALL:1-800-722-1111  
 FOR PRODUCT INFORMATION CALL:1-800-522-6752

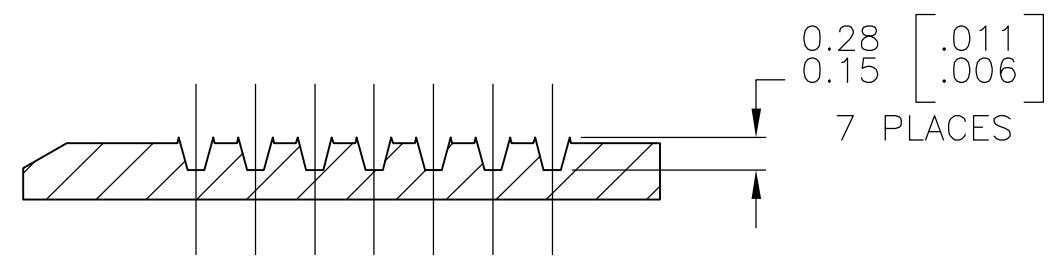
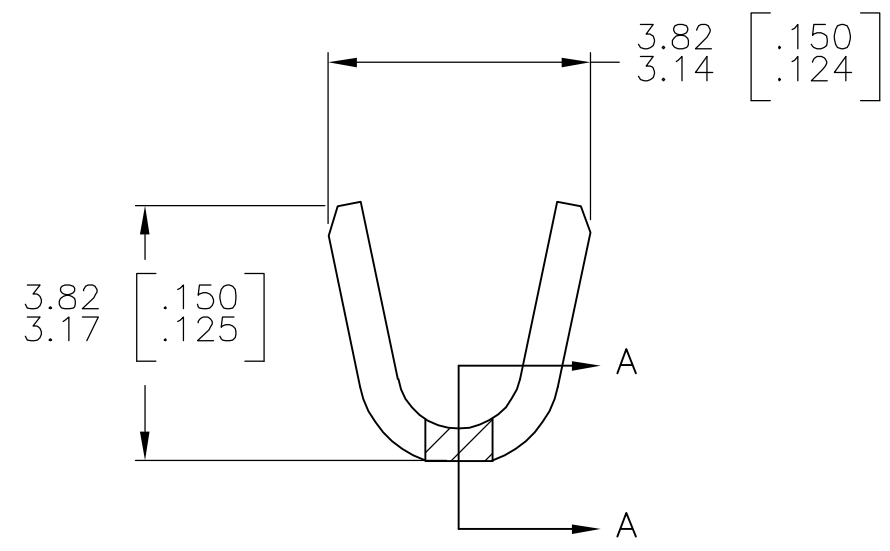
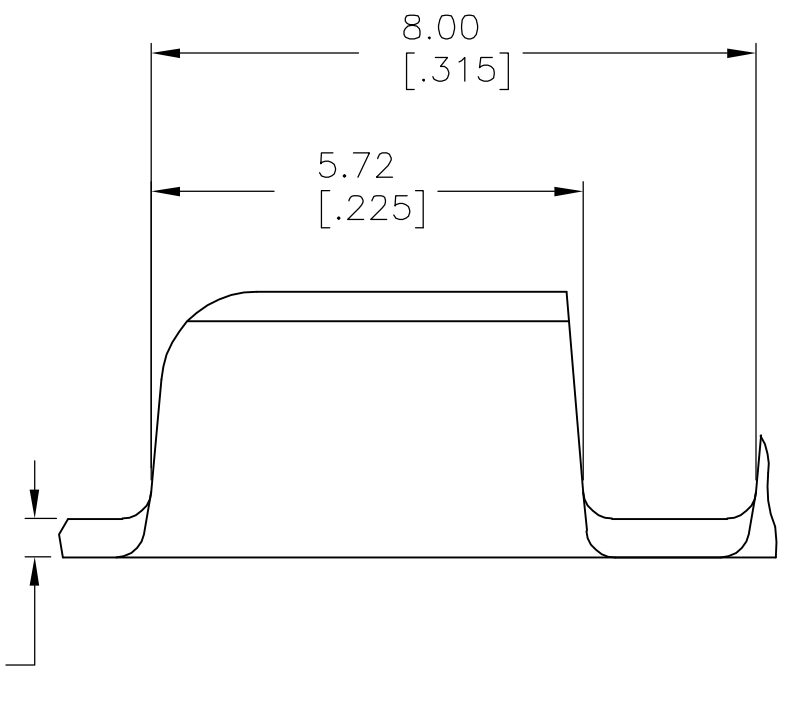

SECTION A-A  
 SCALE 20:1

TIN PLATE	62000-2
-	62000-1
FINISH	PART NO

THIS DRAWING IS A CONTROLLED DOCUMENT.		DWN RAGHAVENDRA 27JUN06	Tyco Electronics Corporation Harrisburg, PA 17105-3608	
DIMENSIONS: mm [INCHES]	TOLERANCES UNLESS OTHERWISE SPECIFIED:	CHK G.D.PORTA	NAME	
	0 PLC ± -	APVD G.D.PORTA	SPLICE, AMPLIVAR	
	1 PLC ± -	PRODUCT SPEC	600-3000 CMA	
	2 PLC ± -	APPLICATION SPEC	SIZE	CAGE CODE
	3 PLC ± 0.38 [.015]	WEIGHT -	A3	00779
	4 PLC ± -	CUSTOMER DRAWING	DRAWING NO	RESTRICTED TO
	ANGLES ± 1' 0"	SCALE 10:1	C-62000	-
MATERIAL BRASS	FINISH SEE TABLE	SHEET 1 OF 1	REV L1	